



Intech International a/s

CONNIE 500 KONTINUERLIG REJEKOGER

Erhvervsparken 16
DK-9700 Brønderslev
Tlf.: + 45 9646 7600
Fax: + 45 9646 7601
E-mail: intech@intechint.dk
www.intechint.dk



Intech International a/s

RUSTFRI KVALITETSUDSTYR TIL ALLE INDUSTRIER
STAINLESS QUALITY EQUIPMENT FOR ALL INDUSTRIES

Connie 500

Kontinuerlig rejekoger

Specifikationer:

Kapacitet:	Op til 800 kg. pr time (ved 3 min kogetid)
Kogetider:	2-7 min.
Opstartstid:	Ca. 60 min. fra 5° til 98°
Vandmængde ved opstart:	Ca. 500 liter.
Oliebrændereffekt:	50 kW.
Olieforbrug:	5 kg. pr time ved max belastning.
Temperaturfald ved standby:	Ca. 2° pr time.

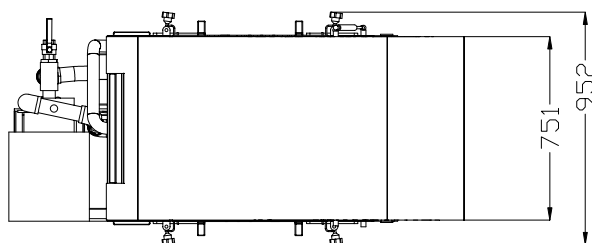
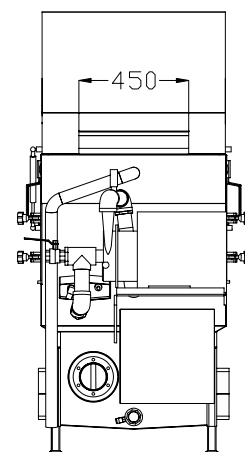
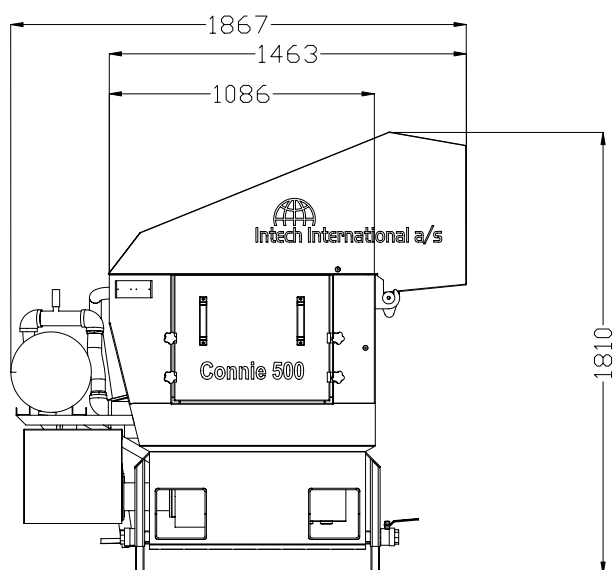

Tekniske data:

Materiale:	Syrefast Rustfrit stål.
Finish:	Poleret (Intech standard)
Strømtilslutning:	3 x 220 eller 3 x 400 volt - 10 amp.
Nettovægt:	Ca. 700 kg.
Bruttovægt:	Ca. 1200 kg